

IG 23 - C with IE Feedback

Model Numbering

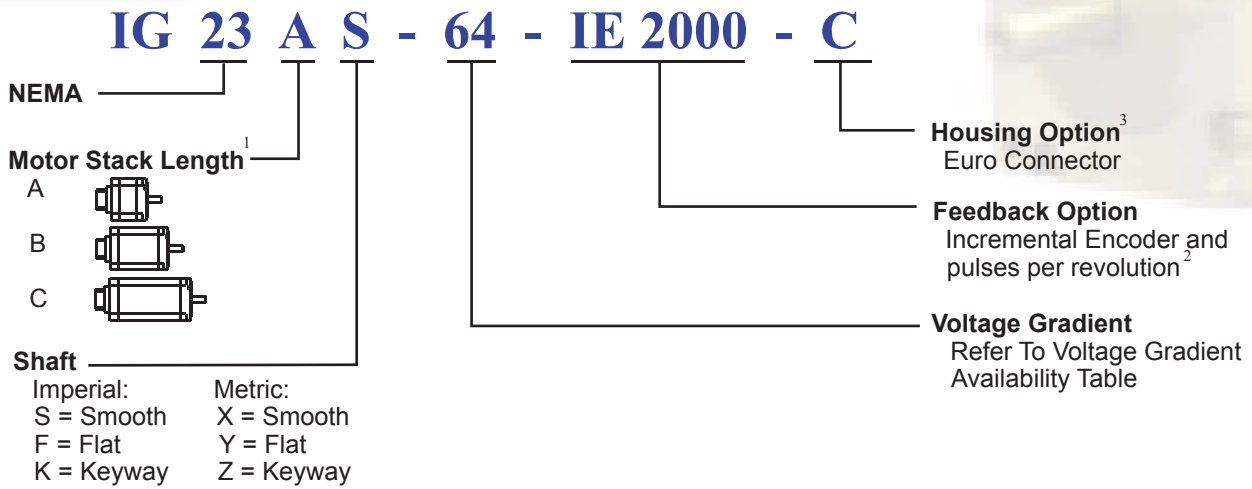

1. Refer to Dimensions for the exact length and shaft options
2. Consult factory for available resolution or refer to Encode Data Table on Page 4
3. All the motors are rated IP64 and by adding front shaft seal it's rating becomes IP65

Voltage Gradient

Voltage Constant K_E (V/kRPM)	8	11	16	22	32	44	64	88	130	180
Frame Size IG 23										

Performance Curves

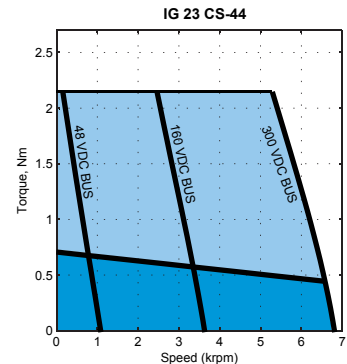
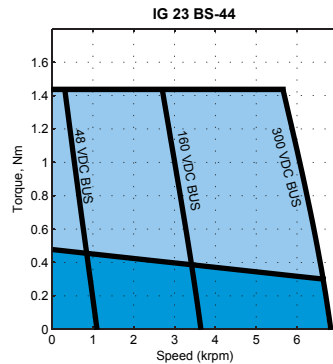
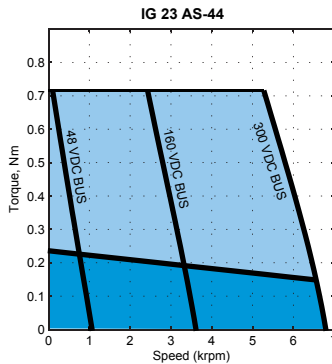

Contact factory for torque-speed curves of other motors

Mar, 08, 06

IG 23 - C with IE Feedback

Motor Specification

NEMA 23																		
Index	Model Number	Weight		Torque Constant (Peak) (L2L)		Voltage Constant	Cont. Stall Torque		Cont. stall current	Peak Stall Torque		Peak Stall Current	Max BEMF (Peak) (L2L)	Max Speed	L-to-L Resistance	L-to-L Inductance	Rotor Inertia	
		W		K _T		K _E	T _{cs}		I _{cs}	T _P		I _P	U _{max}	n _{max}	R	L	J	
		kg	lb	Nm/A	lb-in/A	V/krpm	Nm	lb-in	A	Nm	lb-in	A	V	rpm	Ohms	mH	kg-cm ²	lb-in-sec ²
13	IG 23 AS - 8	0.62	1.37	0.09	0.78	8.00	0.24	2.12	2.72	0.72	6.37	8.16	64.00	8000	0.60	0.72	0.30	0.00027
14	IG 23 BS - 8	0.96	2.12	0.09	0.78	8.00	0.48	4.25	5.44	1.44	12.75	16.32	64.00	8000	0.28	0.35	0.60	0.00053
15	IG 23 CS - 8	1.20	2.65	0.09	0.78	8.00	0.72	6.37	8.16	2.16	19.12	24.48	64.00	8000	0.21	0.24	0.90	0.00080
16	IG 23 AS - 11	0.62	1.37	0.12	1.07	11.00	0.24	2.12	1.98	0.72	6.37	5.94	88.00	8000	1.40	1.90	0.30	0.00027
17	IG 23 BS - 11	0.96	2.12	0.12	1.07	11.00	0.48	4.25	3.96	1.44	12.75	11.87	88.00	8000	0.55	0.75	0.60	0.00053
18	IG 23 CS - 11	1.20	2.65	0.12	1.07	11.00	0.72	6.37	5.94	2.16	19.12	17.81	88.00	8000	0.45	0.60	0.90	0.00080
19	IG 23 AS - 16	0.62	1.37	0.18	1.56	16.00	0.24	2.12	1.36	0.72	6.37	4.08	128.00	8000	2.65	3.20	0.30	0.00027
20	IG 23 BS - 16	0.96	2.12	0.18	1.56	16.00	0.48	4.25	2.72	1.44	12.75	8.16	128.00	8000	1.00	1.35	0.60	0.00053
21	IG 23 CS - 16	1.20	2.65	0.18	1.56	16.00	0.72	6.37	4.08	2.16	19.12	12.24	128.00	8000	0.78	1.10	0.90	0.00080
22	IG 23 AS - 22	0.62	1.37	0.24	2.15	22.00	0.24	2.12	0.99	0.72	6.37	2.97	176.00	8000	5.90	9.30	0.30	0.00027
23	IG 23 BS - 22	0.96	2.12	0.24	2.15	22.00	0.48	4.25	1.98	1.44	12.75	5.94	176.00	8000	2.20	2.90	0.60	0.00053
24	IG 23 CS - 22	1.20	2.65	0.24	2.15	22.00	0.72	6.37	2.97	2.16	19.12	8.90	176.00	8000	1.80	2.40	0.90	0.00080
25	IG 23 AS - 32	0.62	1.37	0.35	3.12	32.00	0.24	2.12	0.68	0.72	6.37	2.04	256.00	8000	15.20	18.20	0.30	0.00027
26	IG 23 BS - 32	0.96	2.12	0.35	3.12	32.00	0.48	4.25	1.36	1.44	12.75	4.08	256.00	8000	6.20	7.10	0.60	0.00053
27	IG 23 CS - 32	1.20	2.65	0.35	3.12	32.00	0.72	6.37	2.04	2.16	19.12	6.12	256.00	8000	4.60	5.70	0.90	0.00080
28	IG 23 AS - 44	0.62	1.37	0.49	4.29	44.00	0.24	2.12	0.49	0.72	6.37	1.48	352.00	8000	28.50	35.60	0.30	0.00027
29	IG 23 BS - 44	0.96	2.12	0.49	4.29	44.00	0.48	4.25	0.99	1.44	12.75	2.97	352.00	8000	11.50	14.10	0.60	0.00053
30	IG 23 CS - 44	1.20	2.65	0.49	4.29	44.00	0.72	6.37	1.48	2.16	19.12	4.45	352.00	8000	9.10	12.30	0.90	0.00080
31	IG 23 AS - 64	0.62	1.37	0.71	6.25	64.00	0.24	2.12	0.34	0.72	6.37	1.02	512.00	8000	67.20	80.90	0.30	0.00027
32	IG 23 BS - 64	0.96	2.12	0.71	6.25	64.00	0.48	4.25	0.68	1.44	12.75	2.04	512.00	8000	26.90	33.10	0.60	0.00053
33	IG 23 CS - 64	1.20	2.65	0.71	6.25	64.00	0.72	6.37	1.02	2.16	19.12	3.06	512.00	8000	21.30	27.60	0.90	0.00080
34	IG 23 AS - 88	0.62	1.37	0.97	8.59	88.00	0.24	2.12	0.25	0.72	6.37	0.74	704.00	8000	107.00	134.50	0.30	0.00027
35	IG 23 BS - 88	0.96	2.12	0.97	8.59	88.00	0.48	4.25	0.49	1.44	12.75	1.48	704.00	8000	43.30	54.50	0.60	0.00053
36	IG 23 CS - 88	1.20	2.65	0.97	8.59	88.00	0.72	6.37	0.74	2.16	19.12	2.23	704.00	8000	35.80	45.20	0.90	0.00080
37	IG 23 AS - 130	0.62	1.37	1.43	12.69	130.00	0.24	2.12	0.17	0.72	6.37	0.50	1,040.00	8000	170.20	212.50	0.30	0.00027
38	IG 23 BS - 130	0.96	2.12	1.43	12.69	130.00	0.48	4.25	0.33	1.44	12.75	1.00	1,040.00	8000	68.50	86.84	0.60	0.00053
39	IG 23 CS - 130	1.20	2.65	1.43	12.69	130.00	0.72	6.37	0.50	2.16	19.12	1.51	1,040.00	8000	56.70	71.80	0.90	0.00080
40	IG 23 AS - 180	0.62	1.37	1.98	17.57	180.00	0.24	2.12	0.12	0.72	6.37	0.36	1,440.00	8000	307.40	406.50	0.30	0.00027
41	IG 23 BS - 180	0.96	2.12	1.98	17.57	180.00	0.48	4.25	0.24	1.44	12.75	0.73	1,440.00	8000	131.00	166.10	0.60	0.00053
42	IG 23 CS - 180	1.20	2.65	1.98	17.57	180.00	0.72	6.37	0.36	2.16	19.12	1.09	1,440.00	8000	101.00	136.70	0.90	0.00080

L2L: Line-to-Line

IG 23 - C with IE Feedback

Motor Drawing

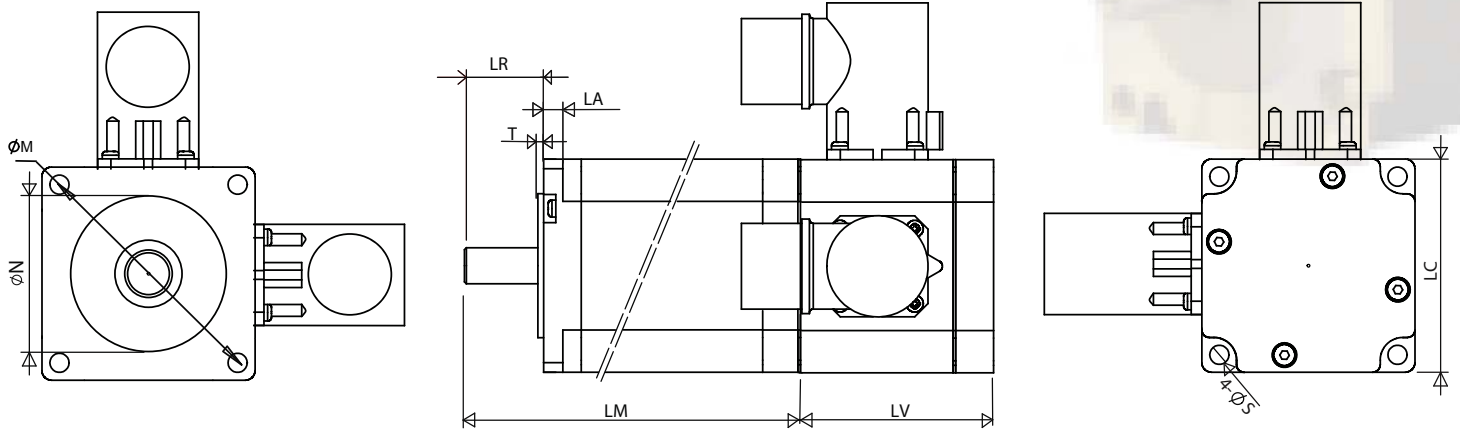

FRONT SHAFT OPTIONS
 (1) SMOOTH SHAFT, AS SHOWN IN THE VIEWS
 (2) KEYWAY SHAFT
 (3) FLAT SHAFT

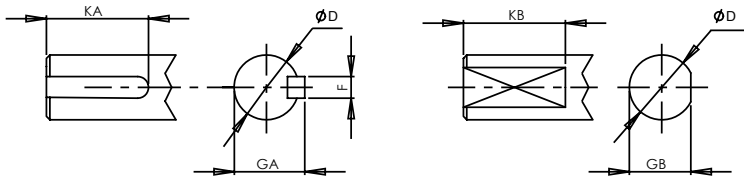

NOTE:
 ALL THE MOTORS ARE RATED IP64 AND BY ADDING FRONT
 SHAFT SEAL, IT'S RATING BECOMES IP65

Units: inches (mm)

IG	LM	LV	LA	T	LR	LC	N	S	M	
23	A	2.795 (71)	2.00 (50.7)	0.20 (5.1)	0.060 (1.5)	0.825 (21)	2.220 (56.4)	1.500 ⁰ _{-0.002} (38.10 ⁰ _{-0.05})	0.200 (5.1)	2.625 (66.68)
	B	3.858 (98)								
	C	4.921 (125)								

Imperial Shaft Option (S/F/K), Units: Inches							Metric Shaft Option (X/Y/Z), Units: mm					
IG	D	F	GA	KA	GB	KB	D	F	GA	KA	GB	KB
23	0.3750 ⁰ _{-0.0005}	0.0938 ⁰ _{-0.001}	0.416 ⁰ _{-0.002}	0.50	0.340 ⁰ _{-0.004}	0.50	10 ⁰ _{-0.013}	3 ⁰ _{-0.025}	11.2 ⁰ _{-0.051}	15	9.0 ⁰ _{-0.1}	15.0

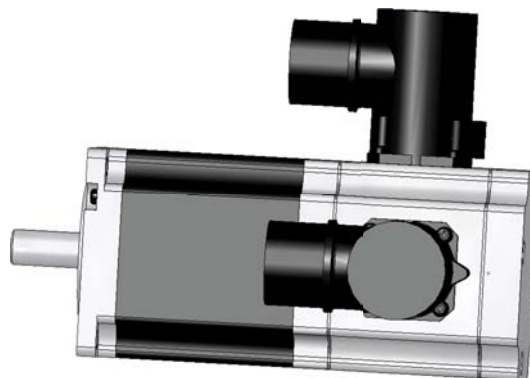

Mar, 08, 06

IG 23- C with IE Feedback

Power Supply

Non Brake Power Wiring Diagram

LEOB 06C PIN	Definition
1	U
2	V
3	GND
4	-
5	-
6	W

Power Connector, Customer View

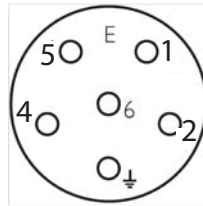

Power Connector: LEOB06CMRSN000
PIN Arrangement

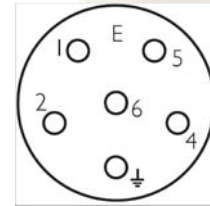

Power Mating Connector: LPRA06BFRDN170
PIN Arrangement

Incremental Encoder

Incremental Encoder Wiring Diagram

SFMB 17G PIN	Wire Code	Definition
1	WHT/BLK	+5VDC
2	BLK/WHT	GND
3	BRN/BLK	A+
4	BLK/BRN	A-
5	BLU/BLK	B+
6	BLK/BLU	B-
7	ORN/BLK	Z+
8	RED/WHT	THERMISTOR 1
9	WHT/RED	THERMISTOR 2
10	BLK/ORN	Z-
11	YEL/BLK	HALL U+
12	BLK/YEL	HALL U-
13	GRN/BLK	HALL V+-
14	BLK/GRN	HALL V-
15	RED/BLK	HALL W+
16	BLK/RED	HALL W-
17	N.C.	-

Encoder Connector, Customer View

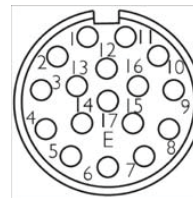

Motor Side: SFMB17GMRSN000
PIN Arrangement

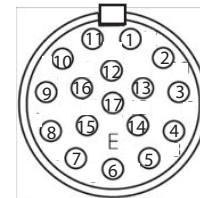

Cable Side: SPNA17HFRON169
PIN Arrangement

Output Waveforms

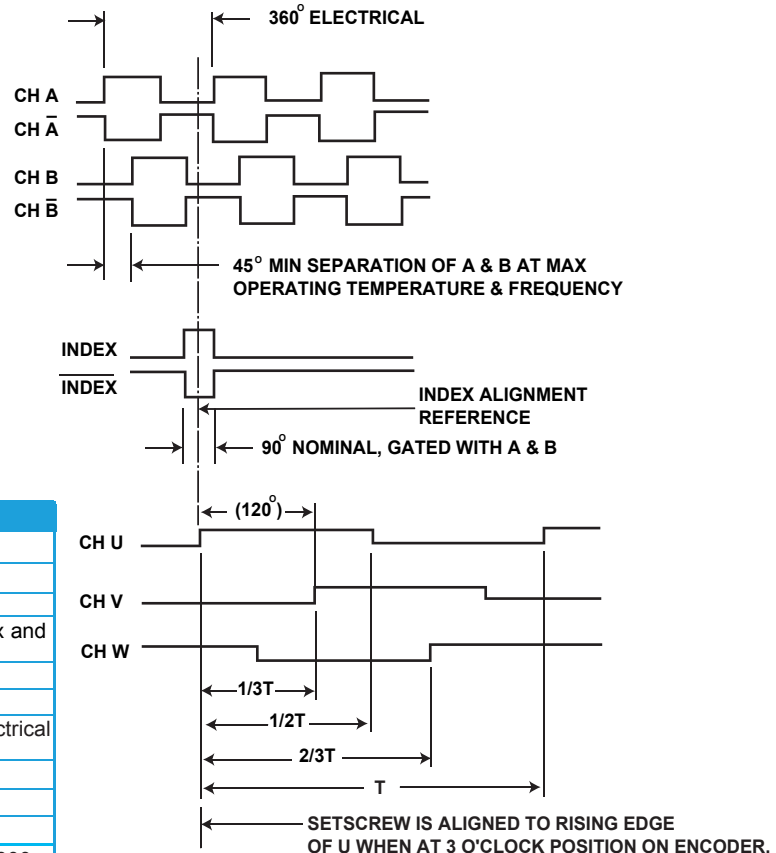

Incremental Encoder Data

Parameter	Values
Input Voltage	5 VDC \pm 10% Single Supply
Input Current Requirement	175 mA
Output Data	Line driver
Output Format	Square wave two channel quadrature with index and commutation signals
Frequency Response	500 kHz
Minimum Edge Separation	45° electrical angle
Commutation Format	Three commutation channels, 4 cycles/360 electrical angle for eight poles
Termination	15 pins JAE P/N F1.W15P.HF interface
Operating Temperature	-30°C to 115°C
Storage Temperature	-40°C to 125°C
Available line counts	250, 256, 500, 512, 1000, 1024, 2000, 2048, 4000, 4096, 8000, 8192 ppr

Mar, 08, 06