

# IG 23 - SB with IE Feedback

## Model Numbering

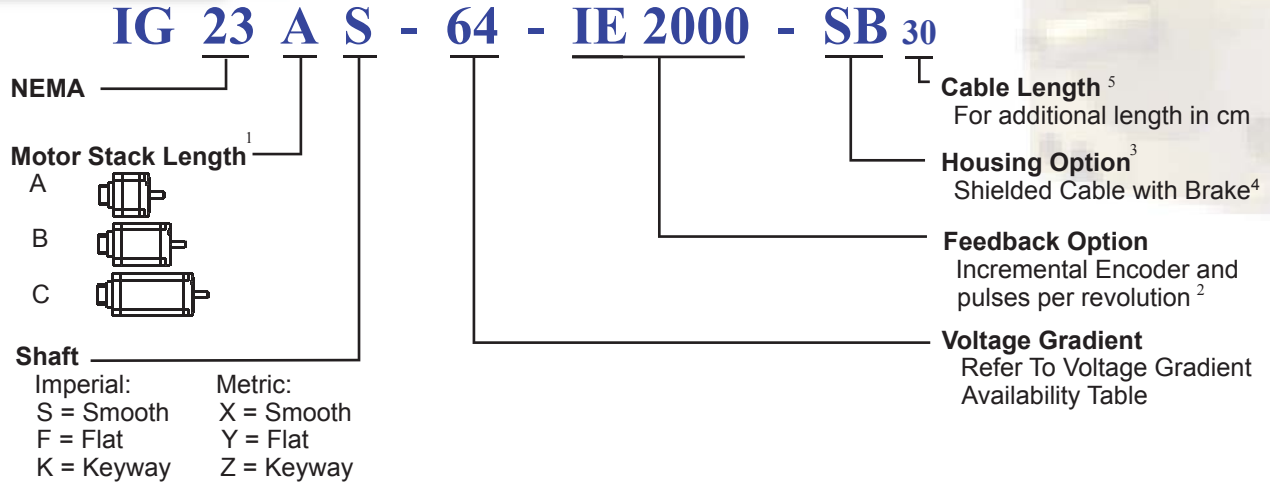

1. Refer to Dimensions for the exact length and shaft options
2. Consult factory for available resolution or refer to Encoder Data Table on page 4
3. All the motors are rated IP64 and by adding front shaft seal it's rating becomes IP65
4. Comes with 18 inches (46 cm) shielded cable
5. Blank For Standard length (18 inches = 46 cm)

## Voltage Gradient

Voltage Constant $K_E$ (V/kRPM)	8	11	16	22	32	44	64	88	130	180
Frame Size IG 23										

## Performance Curves

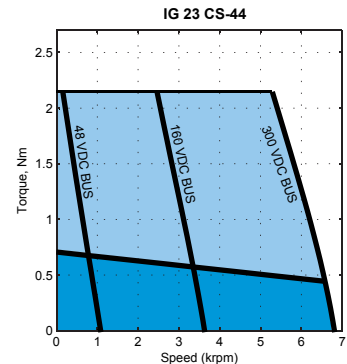
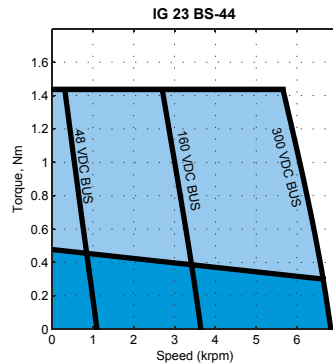
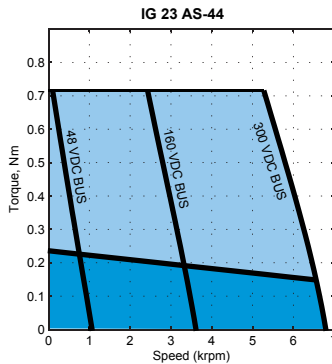

Contact factory for torque-speed curves of other motors

# IG 23 with SB Housing and IE Feedback

## Electrical Specifications

NEMA 23																		
Index	Model Number	Weight		Torque Constant (Peak) (L2L)		Voltage Constant	Cont. Stall Torque		Cont. stall current	Peak Stall Torque		Peak Stall Current	Max BEMF (Peak) (L2L)	Max Speed	L-to-L Resistance	L-to-L Inductance	Rotor Inertia	
		W		K <sub>T</sub>		K <sub>E</sub>	T <sub>cs</sub>		I <sub>cs</sub>	T <sub>P</sub>		I <sub>P</sub>	U <sub>max</sub>	n <sub>max</sub>	R	L	J	
		kg	lb	Nm/A	lb-in/A	V/krpm	Nm	lb-in	A	Nm	lb-in	A	V	rpm	Ohms	mH	kg-cm <sup>2</sup>	lb-in-sec <sup>2</sup>
13	IG 23 AS - 8	0.62	1.37	0.09	0.78	8.00	0.24	2.12	2.72	0.72	6.37	8.16	64.00	8000	0.60	0.72	0.30	0.00
14	IG 23 BS - 8	0.96	2.12	0.09	0.78	8.00	0.48	4.25	5.44	1.44	12.75	16.32	64.00	8000	0.28	0.35	0.60	0.00
15	IG 23 CS - 8	1.20	2.65	0.09	0.78	8.00	0.72	6.37	8.16	2.16	19.12	24.48	64.00	8000	0.21	0.24	0.90	0.00
16	IG 23 AS - 11	0.62	1.37	0.12	1.07	11.00	0.24	2.12	1.98	0.72	6.37	5.94	88.00	8000	1.40	1.90	0.30	0.00
17	IG 23 BS - 11	0.96	2.12	0.12	1.07	11.00	0.48	4.25	3.96	1.44	12.75	11.87	88.00	8000	0.55	0.75	0.60	0.00
18	IG 23 CS - 11	1.20	2.65	0.12	1.07	11.00	0.72	6.37	5.94	2.16	19.12	17.81	88.00	8000	0.45	0.60	0.90	0.00
19	IG 23 AS - 16	0.62	1.37	0.18	1.56	16.00	0.24	2.12	1.36	0.72	6.37	4.08	128.00	8000	2.65	3.20	0.30	0.00
20	IG 23 BS - 16	0.96	2.12	0.18	1.56	16.00	0.48	4.25	2.72	1.44	12.75	8.16	128.00	8000	1.00	1.35	0.60	0.00
21	IG 23 CS - 16	1.20	2.65	0.18	1.56	16.00	0.72	6.37	4.08	2.16	19.12	12.24	128.00	8000	0.78	1.10	0.90	0.00
22	IG 23 AS - 22	0.62	1.37	0.24	2.15	22.00	0.24	2.12	0.99	0.72	6.37	2.97	176.00	8000	5.90	9.30	0.30	0.00
23	IG 23 BS - 22	0.96	2.12	0.24	2.15	22.00	0.48	4.25	1.98	1.44	12.75	5.94	176.00	8000	2.20	2.90	0.60	0.00
24	IG 23 CS - 22	1.20	2.65	0.24	2.15	22.00	0.72	6.37	2.97	2.16	19.12	8.90	176.00	8000	1.80	2.40	0.90	0.00
25	IG 23 AS - 32	0.62	1.37	0.35	3.12	32.00	0.24	2.12	0.68	0.72	6.37	2.04	256.00	8000	15.20	18.20	0.30	0.00
26	IG 23 BS - 32	0.96	2.12	0.35	3.12	32.00	0.48	4.25	1.36	1.44	12.75	4.08	256.00	8000	6.20	7.10	0.60	0.00
27	IG 23 CS - 32	1.20	2.65	0.35	3.12	32.00	0.72	6.37	2.04	2.16	19.12	6.12	256.00	8000	4.60	5.70	0.90	0.00
28	IG 23 AS - 44	0.62	1.37	0.49	4.29	44.00	0.24	2.12	0.49	0.72	6.37	1.48	352.00	8000	28.50	35.60	0.30	0.00
29	IG 23 BS - 44	0.96	2.12	0.49	4.29	44.00	0.48	4.25	0.99	1.44	12.75	2.97	352.00	8000	11.50	14.10	0.60	0.00
30	IG 23 CS - 44	1.20	2.65	0.49	4.29	44.00	0.72	6.37	1.48	2.16	19.12	4.45	352.00	8000	9.10	12.30	0.90	0.00
31	IG 23 AS - 64	0.62	1.37	0.71	6.25	64.00	0.24	2.12	0.34	0.72	6.37	1.02	512.00	8000	67.20	80.90	0.30	0.00
32	IG 23 BS - 64	0.96	2.12	0.71	6.25	64.00	0.48	4.25	0.68	1.44	12.75	2.04	512.00	8000	26.90	33.10	0.60	0.00
33	IG 23 CS - 64	1.20	2.65	0.71	6.25	64.00	0.72	6.37	1.02	2.16	19.12	3.06	512.00	8000	21.30	27.60	0.90	0.00
34	IG 23 AS - 88	0.62	1.37	0.97	8.59	88.00	0.24	2.12	0.25	0.72	6.37	0.74	704.00	8000	107.00	134.50	0.30	0.00
35	IG 23 BS - 88	0.96	2.12	0.97	8.59	88.00	0.48	4.25	0.49	1.44	12.75	1.48	704.00	8000	43.30	54.50	0.60	0.00
36	IG 23 CS - 88	1.20	2.65	0.97	8.59	88.00	0.72	6.37	0.74	2.16	19.12	2.23	704.00	8000	35.80	45.20	0.90	0.00
37	IG 23 AS - 130	0.62	1.37	1.43	12.69	130.00	0.24	2.12	0.17	0.72	6.37	0.50	1,040.00	8000	170.20	212.50	0.30	0.00
38	IG 23 BS - 130	0.96	2.12	1.43	12.69	130.00	0.48	4.25	0.33	1.44	12.75	1.00	1,040.00	8000	68.50	86.84	0.60	0.00
39	IG 23 CS - 130	1.20	2.65	1.43	12.69	130.00	0.72	6.37	0.50	2.16	19.12	1.51	1,040.00	8000	56.70	71.80	0.90	0.00
40	IG 23 AS - 180	0.62	1.37	1.98	17.57	180.00	0.24	2.12	0.12	0.72	6.37	0.36	1,440.00	8000	307.40	406.50	0.30	0.00
41	IG 23 BS - 180	0.96	2.12	1.98	17.57	180.00	0.48	4.25	0.24	1.44	12.75	0.73	1,440.00	8000	131.00	166.10	0.60	0.00
42	IG 23 CS - 180	1.20	2.65	1.98	17.57	180.00	0.72	6.37	0.36	2.16	19.12	1.09	1,440.00	8000	101.00	136.70	0.90	0.00

L2L: Line-to-Line

# IG 23 with SB Housing and IE Feedback

## Motor Drawing

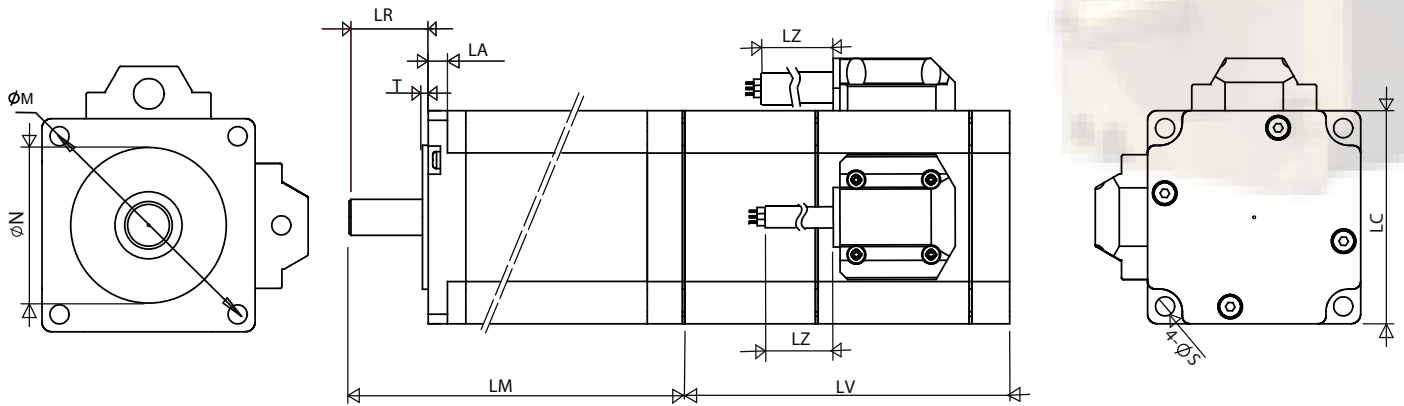

FRONT SHAFT OPTIONS  
 (1) SMOOTH SHAFT, AS SHOWN IN THE VIEWS  
 (2) KEYWAY SHAFT  
 (3) FLAT SHAFT

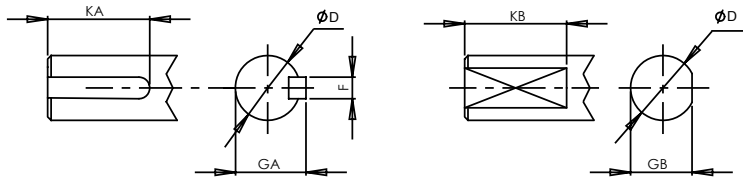

NOTE:  
 ALL THE MOTORS ARE RATED IP64 AND BY ADDING FRONT  
 SHAFT SEAL, IT'S RATING BECOMES IP65

Units: inches (mm)

IG		LM	LV	LA	T	LR	LC	LZ	N	S	M
23	A	2.795 (71)	3.38 (85.9)	0.20 (5.1)	0.060 (1.5)	0.825 (21)	2.220 (56.4)	18 (457.2)	1.500 <sup>0</sup> <sub>-0.002</sub> (38.10 <sup>0</sup> <sub>-0.05</sub> )	0.200 (5.1)	2.625 (66.68)
	B	3.858 (98)									
	C	4.921 (125)									

IG	Imperial Shaft Option (S/F/K), Units: Inches						Metric Shaft Option (X/Y/Z), Units: mm					
	D	F	GA	KA	GB	KB	D	F	GA	KA	GB	KB
23	0.3750 <sup>0</sup> <sub>-0.0005</sub>	0.0938 <sup>0</sup> <sub>-0.001</sub>	0.416 <sup>0</sup> <sub>-0.002</sub>	0.50	0.340 <sup>0</sup> <sub>-0.004</sub>	0.50	10 <sup>0</sup> <sub>-0.013</sub>	3 <sup>0</sup> <sub>-0.025</sub>	11.2 <sup>0</sup> <sub>-0.051</sub>	15	9.0 <sup>0</sup> <sub>-0.1</sub>	15.0

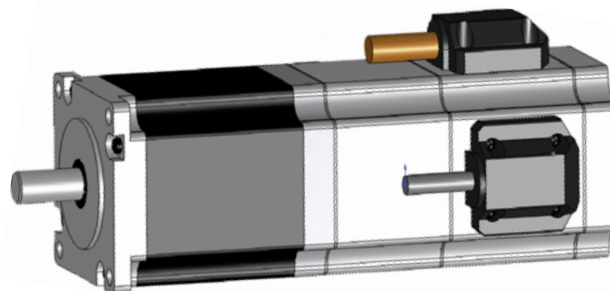

Mar, 20, 06

# IG 23 with SB Housing and IE Feedback



## Power Cable Wire Code

### Power Cable for Brake Wire Code

Wire Code	Function
WIRE #1	PHASE U
WIRE #2	PHASE V
WIRE #3	PHASE W
WIRE #4	Brake 1
WIRE #5	Brake 2
GRN/YEL	Ground
Shield	Shield

SAB CC600CYT, 7 Pins, AWG16/20 (depending on current), 600V, 105C, UL, CE, CSA

### 24vdc Fail-Safe Brake Data

IG	Supply Power (mA)	Holding Torque lb-in (Nm)
23	375	5 (0.56)

## Incremental Encoder

### Encoder Wiring Diagram

Function	Color
CH A	BRN with BLK
CH A-	BLK with BRN
CH B	BLU with BLK
CH B-	BLK with BLU
INDEX	ORN with BLK
INDEX-	BLK with ORN
CH U	YEL with BLK
CH U-	BLK with YEL
CH V	GRN with BLK
CH V-	BLK with GRN
CH W	RED with BLK
CH W-	BLK with RED
+5VDC	WHT with BLK
GND	BLK with WHT
Thermistor 1	RED with WHT
Thermistor 2	WHT with RED
SHIELD	SHIELD

### Incremental Encoder Output Waveforms

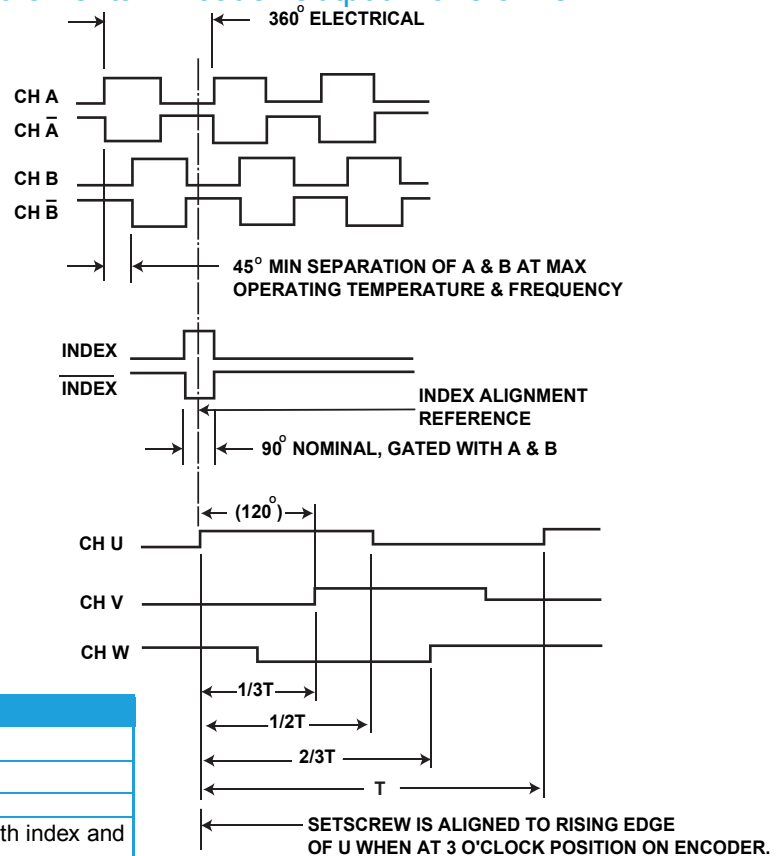

### Incremental Encoder Data

Parameter	Values
Input Voltage	5 VDC $\pm$ 10% Single Supply
Input Current Requirement	175 mA
Output Data	Line driver
Output Format	Square wave two channel quadrature with index and commutation signals
Frequency Response	500 kHz
Minimum Edge Separation	45° electrical angle
Commutation Format	Three commutation channels, 4 cycles/360 electrical angle for eight poles
Termination	15 pins JAE P/N F1.W15P.HF interface
Operating Temperature	-30°C to 115°C
Storage Temperature	-40°C to 125°C
Available line counts	250, 256, 500, 512, 1000, 1024, 2000, 2048, 4000, 4096, 8000, 8192 ppr

Mar, 20, 06